

BAÑO MARÍA VITRINA CALIENTE

Modelo
CA

- Control de temperatura mediante Termostato 20-90°C.
- Desagüe incorporado.
- Interruptores de funcionamiento impermeabilizados con fuelle exterior.
- Aislamiento Térmico de la vitrina con lana de roca Euro Clase A1.
- Puertas Correderas en metacrilato.
- Cuba Interior fabricada en Acero Inoxidable AISI-304.
- Iluminación LED.
- Cristal templado de seguridad.

RECOMENDABLE
NO SOBREPASAR LOS 70°C.

CRISTAL
RECTO



CRISTAL
CURVO



Temperatura
de Trabajo +20°/+90°

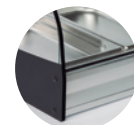

PLATA



NOGAL



BLANCO

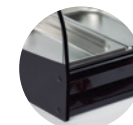

NEGRO

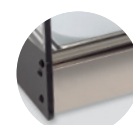

ACERO
INOXIDABLE

Iluminación
LED



CA-6 NOGAL



Cubetas
INCLUIDAS

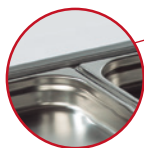

Fabricación Especial
A MEDIDA
Pídanos Presupuesto

SUPLEMENTO CUBETA
MELAMINA 1/3 h40
4 uds. 6 uds. 8 uds.
48 € 72 € 96 €

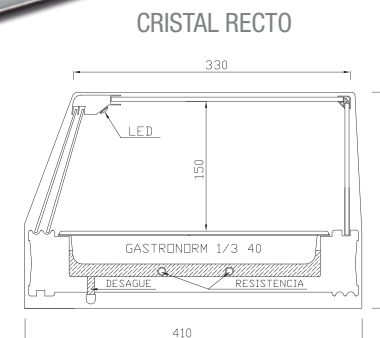
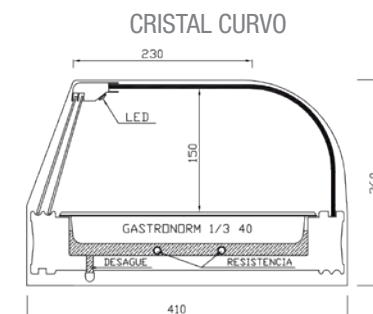

Bandeja Auxiliar
INCLUIDA



- Vitrina caliente de **BAÑO MARIA** Ideal para el exposición de tapas calientes en Cubeta Gastronorm incluidas en la vitrina.
- Disponible con bandeja plana en Acero Inoxidable para utilizarla sin cubetas o como **EXPOSITOR NEUTRO**.

Modelo	Largo	Fondo	Alto	Cubetas (Incluidas)	Potencia
CA-4 CA-4R	810	410	260	4	704 W / 230 V
CA-6 CA-6R	1160	410	260	6	1006 W / 230 V
CA-8 CA-8R	1516	410	260	8	1308 W / 230 V