

MTE40



Product Family	Minibars
Installation	Free standing
Category	One Door
Cooling type	Thermo-Electric
Defrost	Automatic
Hinge type	Standard
Hinge position	Right
Reversible door	Yes
EAN code	8017709312541



Aesthetics

Colour	Black
Material	Plastic
Handle	Integrated
Logo colour	Chrome
Side material	Steel
Side colour	Black
Logo	Silk screen

Refrigerator compartment features



No. of adjustable shelves	2
Type of adjustable shelves	Glass
Internal light in fridge	Yes
Type of internal light (fridge)	LED

Refrigerator Inner Door

Number of adjustable door shelves	1
No. of bottle shelves	1

Other technical features

Refrigerant gas type	R600a	Refrigerant Quantity (gr)	25 g
----------------------	-------	---------------------------	------

Performance / Energy Label

Airborne acoustical noise emissions 21 dB(A) re 1pW

Performance / Energy Label NEW 2019



Annual energy consumption	161 kWh/a
Energy efficiency class	G
Airborne acoustical noise emission class	A
Total net volume	32 l
Sum of the volumes of the chill compartment(s) and the unfrozen compartment(s)	32 l
Total gross volume	40 l
Climate class	N
EEl	205 %

Electrical Connection

Plug	(F;E) Schuko
Electrical connection rating	65 W
Voltage (V)	230 V
Frequency (Hz)	50/60 Hz
Power supply cable length	150 cm

Logistic Information

Width	406 mm
Depth without handle	433 mm
Height	539 mm
Product width with maximum doors opening	600 mm
Product depth with doors open at 90°	823 mm

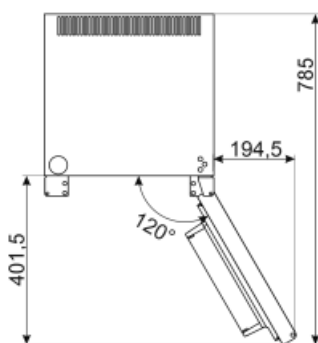
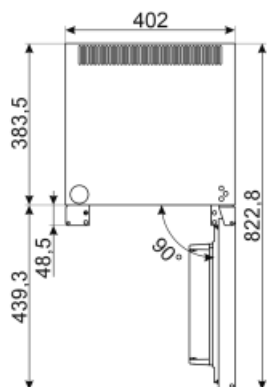
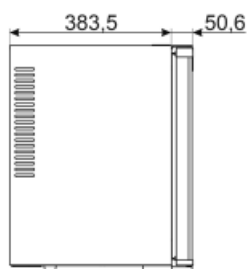
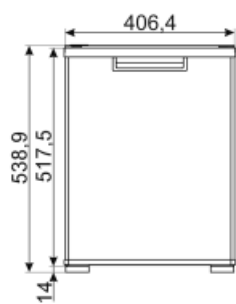

Symbols glossary (TT)



The automatic defrost system works by automatically defrosting at regular intervals eliminating the need to defrost altogether.



LED interior lighting: is a more energy efficient and long lasting way of illuminating the interior of the appliance.



Energy efficiency class G