



Project:
Item Number:
Quantity:

INTERNATIONAL CONVEYOR TOASTERS - 250-350 SLICES PER HOUR* (MODELS JT1, JT1H)



JT1



JT1H

DESCRIPTION

Vollrath's 250-350 slice per hour conveyor toasters feature easy to use conveyor control to perfectly toast a variety of bread products - from sliced bread to buns and bagels. These toasters are well suited for lower volume applications such as self-serve breakfast buffets and to replace pop-up toasters.

AGENCY LISTINGS



** Slices per hour is based on maximum conveyor speed. Conveyor speed determines toasting time and affects color and texture of the toast. Results may vary based upon type of bread, color and texture preference.*

Due to continued product improvement, please consult www.vollrath.com for current product specifications.

ITEMS

Item No.	Model No.	Description
CT2-23035003	JT1	350 Slices Per Hour*
CT2-23035002		
CT2H-23025003	JT1H	250 Slices Per Hour*, High Clearance
CT2H-23025002		

FEATURES

- Stainless steel and aluminized steel construction.
- Variable speed control allows for real-time adjustments.
- 10½" (26.7 cm) 2-slice wide conveyor is larger than industry standard for better toasting results.
- Forced convection toasting promotes uniform results and energy efficiency.
- Energy efficient, fast reacting, quartz heaters.
- High-quality, insulated wires help prevent against dry rotting and cracking.
- High-temperature thermoplastic terminal blocks with stainless steel clamping provides superior connections; designed for ease of serviceability.
- Maintenance-free drive system; stainless steel drive chain does not require lubrication.
- Standby mode saves up to 75 percent energy during slow periods when unit is not in use and allows machine to quickly return to full power.
- Adjustable legs.
- Made in the USA.

WARRANTY

- Warrantied parts: The warranty period is 2 year parts, 1 year labor.
- Heater tubes: The warranty period is 1 year, including labor when performed at an authorized service center. Heater tube glass damage is not covered by this warranty.
- For full warranty details, please refer to www.Vollrath.com.

CLEARANCE AND ENVIRONMENT REQUIREMENTS

- Do not place on surfaces or near walls, partitions or kitchen furniture unless they are made of non-combustible material or clad with non-combustible heat-insulating material. Toasters must not be used near or below curtains and other combustible materials.
- Maximum ambient temperature: 104° F (40 ° C).

Approvals	Date

The Vollrath Company, L.L.C. Headquarters
1236 North 18th Street
Sheboygan, Wisconsin
53081-3201 USA
Main Tel: 800-624-2051 or 920-457-4851
Main Fax: 800-752-5620 or 920-459-6573
Canada Customer Service: 800-695-8560
Tech Services: techservices@vollrathco.com
www.vollrath.com

Pujadas
Ctra. de Castanyet,
132 P.O. Box 121
17430 Santa Coloma de Farners
(Girona) – Spain
Tel. +34-972-84-32-01
info@pujadas.es

Vollrath of China
Vollrath Shanghai Trading Limited
Room 201, Building A
Xin Yi Plaza
1618 Yi Shan Road
Shanghai, 201103
China, P.R.C.
Tel: +86-21-5058-9580

Vollrath de Mexico S. de R.L. de C.V.
Periferico Sur No. 7980 Edificio 4-E
Col. Santa Maria Tequepexpan
45600 Tlaquepaque, Jalisco | Mexico
Tel: (52) 333-133-6767
Tel: (52) 333-133-6769
Fax: (52) 333-133-6768

INTERNATIONAL CONVEYOR TOASTERS - 250-350 SLICES PER HOUR* (MODELS JT1, JT1H)

DIMENSIONS (Shown in inches (cm))

JT1

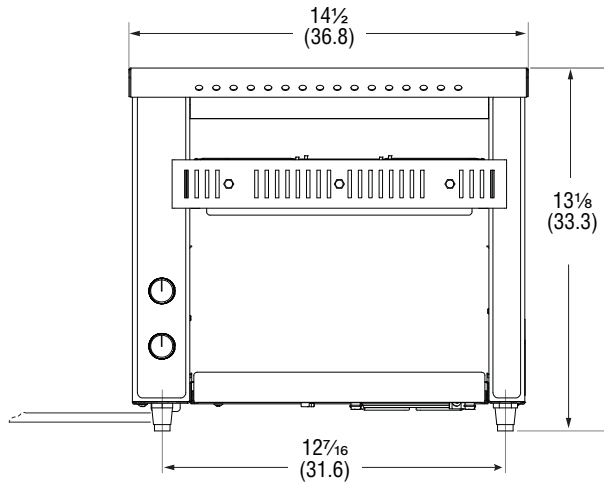

Front View

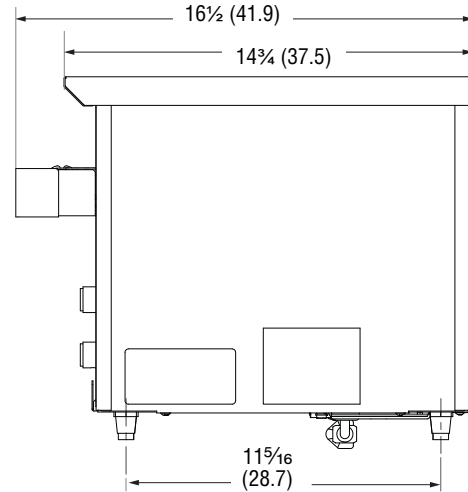

Side View

JT1H

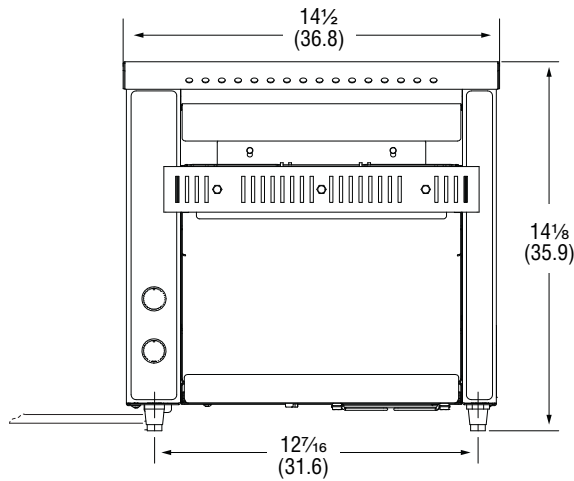

Front View

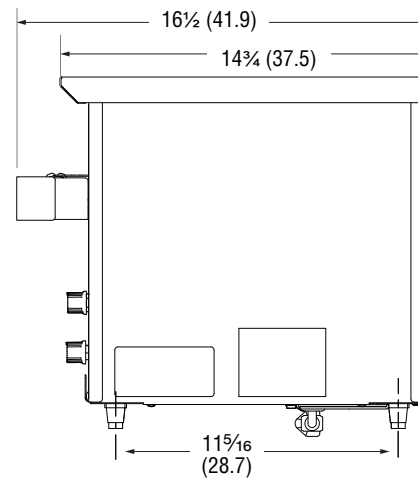

Side View

SPECIFICATIONS

Item No.	Model	Slices or Bun Halves per Hour* (Up To)	Product Opening In (CM)	Voltage	Maximum Watts	Amps	Hz	Weight LB (KG)	Plug
CT2-23035003	JT1	350	1 3/8 (3.2)	220-240	1900	7.6	50/60	35 (15.9)	UK
CT2-23035002									Schuko
CT2H-23025003	JT1H	250	1-2 1/8 (2.5-7.6)						UK
CT2H-23025002									Schuko

Receptacles

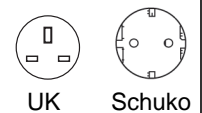

* Slices per hour is based on maximum conveyor speed. Conveyor speed determines toasting time and affects color and texture of the toast. Results may vary based upon type of bread, color and texture preference.

The Vollrath Company, L.L.C. Headquarters
 1236 North 18th Street
 Sheboygan, Wisconsin
 53081-3201 USA
 Main Tel: 800-624-2051 or 920-457-4851
 Main Fax: 800-752-5620 or 920-459-6573
 Canada Customer Service: 800-695-8560
 Tech Services: techservicereps@vollrathco.com
 www.vollrath.com

Pujadas
 Ctra. de Castanyet,
 132 P.O. Box 121
 17430 Santa Coloma de Farners
 (Girona) - Spain
 Tel. +34-972-84-32-01
 info@pujadas.es

Vollrath of China
 Vollrath Shanghai Trading Limited
 Room 201, Building A
 Xin Yi Plaza
 1618 Yi Shan Road
 Shanghai, 201103
 China, P.R.C.
 Tel: +86-21-5058-9580

Vollrath de Mexico S. de R.L. de C.V.
 Periferico Sur No. 7980 Edificio 4-E
 Col. Santa Maria Tequepexpan
 45600 Tlaquepaque, Jalisco | Mexico
 Tel: (52) 333-133-6767
 Tel: (52) 333-133-6769
 Fax: (52) 333-133-6768



Project:
Item Number:
Quantity:

INTERNATIONAL CONVEYOR TOASTERS - 550-800 SLICES PER HOUR* (JT2, JT2H)



JT2



JT2H

DESCRIPTION

Vollrath's 550-800 slices per hour conveyor toasters feature easy-to-use conveyor control and variable top and bottom heat control to perfectly toast and warm a variety of bread products – bread, buns, rolls, bagels, waffles, pita bread, Texas toast and English muffins. These toasters provide mid-size restaurants with the flexibility to a variety of bread products for breakfast and lunch menu items.

WARRANTY

- Warrantied parts: The warranty period is 2 year parts, 1 year labor.
- Heater tubes: The warranty period is 1 year parts and labor. Heater tube glass damage is not covered by this warranty.
- For full warranty details, please refer to www.Vollrath.com.

AGENCY LISTINGS



** Slices per hour is based on maximum conveyor speed. Conveyor speed determines toasting time and affects color and texture of the toast. Results may vary based upon type of bread, color and texture preference.*

Due to continued product improvement, please consult www.vollrath.com for current product specifications.

ITEMS

Item No.	Model	Description
CT4-23080003	JT2	800 Slices Per Hour*, UK
CT4-23080002		800 Slices Per Hour*, Schuko
CT4H-23055003	JT2H	550 Slices Per Hour*, UK, High Clearance
CT4H-23055002		550 Slices Per Hour*, Schuko, High Clearance

FEATURES

- Stainless steel and aluminized steel construction.
- Variable speed control allows for real-time adjustments.
- Variable top and bottom heat control.
- 10½" (26.7 cm) 2-slice wide conveyor is larger than industry standard for better toasting results.
- Product entry opening on high clearance toasters can be adjusted from 1½" (3.8 cm) to 3" (7.6).
- Forced convection toasting promotes uniform results and energy efficiency.
- Energy efficient, fast reacting, quartz heaters.
- High-temperature bearings ensure smooth operation and do not require lubrication.
- High-quality, insulated wires help prevent against dry rotting and cracking.
- High-temperature thermoplastic terminal blocks with stainless steel clamping provides superior connections; designed for ease of serviceability.
- Maintenance-free drive system; stainless steel drive chain does not require lubrication.
- Fan control switch senses temperature of unit and keeps fan running until unit is completely cool.
- Standby mode saves up to 75 percent energy during slow periods when unit is not in use and allows machine to quickly return to full power.
- Adjustable legs.
- 4½ ft. (1.4 m) cord with plug.
- Made in the USA.

CLEARANCE AND ENVIRONMENT REQUIREMENTS

- Do not place on surfaces or near walls, partitions or kitchen furniture unless they are made of non-combustible material or clad with non-combustible heat-insulating material. Toasters must not be used near or below curtains and other combustible materials.
- Maximum ambient temperature: 104° F (40 ° C).

Approvals	Date

The Vollrath Company, L.L.C. Headquarters
1236 North 18th Street
Sheboygan, Wisconsin
53081-3201 USA
Main Tel: 800-624-2051 or 920-457-4851
Main Fax: 800-752-5620 or 920-459-6573
Canada Customer Service: 800-695-8560
Tech Services: techservices@vollrathco.com
www.vollrath.com

Pujadas
Ctra. de Castanyet,
132 P.O. Box 121
17430 Santa Coloma de Farners
(Girona) – Spain
Tel. +34-972-84-32-01
info@pujadas.es

Vollrath of China
Vollrath Shanghai Trading Limited
Room 201, Building A
Xin Yi Plaza
1618 Yi Shan Road
Shanghai, 201103
China, P.R.C.
Tel: +86-21-5058-9580

Vollrath de Mexico S. de R.L. de C.V.
Periferico Sur No. 7980 Edificio 4-E
Col. Santa Maria Tequepexpan
45600 Tlaquepaque, Jalisco | Mexico
Tel: (52) 333-133-6767
Tel: (52) 333-133-6769
Fax: (52) 333-133-6768

INTERNATIONAL CONVEYOR TOASTERS - 550-800 SLICES PER HOUR* (JT2, JT2H)

DIMENSIONS (Shown in inches (cm))

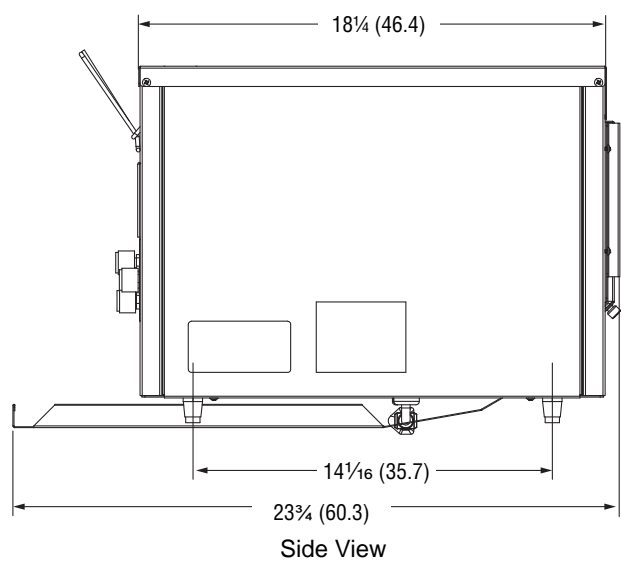
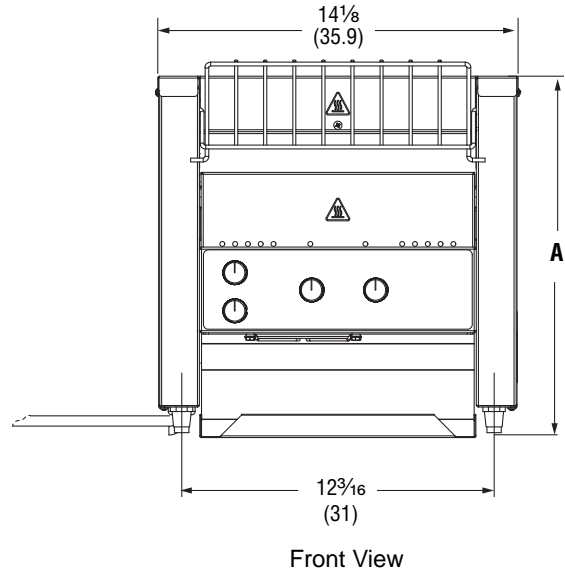

SPECIFICATIONS

Item No.	Model	Slices or Bun Halves per Hour (Up to)*	Product Opening IN (CM)	Voltage	Maximum Watts	Amps	Hz	(A) Height IN (CM)	Weight LB (KG)	Plug
CT4-23080003	JT2	800	1 1/2 (3.8)	220-240	2800	11.2	50/60	14 (35.6)	45 (20.4)	UK
CT4-23080002								Schuko		
CT4H-23055003	JT2H	550	Adjustable 1 1/2 - 3 (3.8 - 7.6)					15 1/8 (38.4)		UK
CT4H-23055002								Schuko		

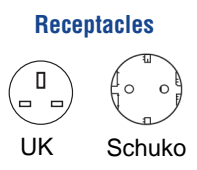

* Slices per hour is based on maximum conveyor speed. Conveyor speed determines toasting time and affects color and texture of the toast. Results may vary based upon type of bread, color and texture preference.

The Vollrath Company, L.L.C. Headquarters
 1236 North 18th Street
 Sheboygan, Wisconsin
 53081-3201 USA
 Main Tel: 800-624-2051 or 920-457-4851
 Main Fax: 800-752-5620 or 920-459-6573
 Canada Customer Service: 800-695-8560
 Tech Services: techservicereps@vollrathco.com
 www.vollrath.com

Pujadas
 Ctra. de Castanyet,
 132 P.O. Box 121
 17430 Santa Coloma de Farners
 (Girona) - Spain
 Tel. +34-972-84-32-01
 info@pujadas.es

Vollrath of China
 Vollrath Shanghai Trading Limited
 Room 201, Building A
 Xin Yi Plaza
 1618 Yi Shan Road
 Shanghai, 201103
 China, P.R.C.
 Tel: +86-21-5058-9580

Vollrath de Mexico S. de R.L. de C.V.
 Periferico Sur No. 7980 Edificio 4-E
 Col. Santa Maria Tequepexpan
 45600 Tlaquepaque, Jalisco | Mexico
 Tel: (52) 333-133-6767
 Tel: (52) 333-133-6769
 Fax: (52) 333-133-6768



Project:
Item Number:
Quantity:

INTERNATIONAL CONVEYOR TOASTERS - 950-1,000 SLICES PER HOUR* (JT3, JT3H)



JT3



JT3H

DESCRIPTION

Vollrath's 950-1,000 slices per hour conveyor toasters feature easy-to-use conveyor control and variable top and bottom heat control to perfectly toast and warm a variety of bread products – bread, buns, rolls, bagels, waffles, pita bread, Texas toast and English muffins. They provide high-volume with the flexibility to toast a variety of bread products for breakfast and lunch menu items.

WARRANTY

- Warrantied parts: The warranty period is 2 year parts, 1 year labor.
- Heater tubes: The warranty period is 1 year parts and labor. Heater tube glass damage is not covered by this warranty.
- For full warranty details, please refer to www.Vollrath.com.

AGENCY LISTINGS



** Slices per hour is based on maximum conveyor speed. Conveyor speed determines toasting time and affects color and texture of the toast. Results may vary based upon type of bread, color and texture preference.*

Due to continued product improvement, please consult www.vollrath.com for current product specifications.

ITEMS

Item No.	Model	Description
CT4-2301000	JT3	1,000 Slices Per Hour*
CT4H-230950	JT3H	950 Slices Per Hour*, High Clearance

FEATURES

- Stainless steel and aluminized steel construction.
- Variable speed control allows for real-time adjustments.
- Variable top and bottom heat control.
- 14½" (36.8 cm) 3-slice wide conveyor is larger than industry standard for better toasting results.
- Product entry opening on high clearance toasters can be adjusted from 1½" (3.8 cm) to 3" (7.6).
- Forced convection toasting promotes uniform results and energy efficiency.
- Energy efficient, fast reacting, quartz heaters.
- High-temperature bearings ensure smooth operation and do not require lubrication.
- High-quality, insulated wires help prevent against dry rotting and cracking.
- High-temperature thermoplastic terminal blocks with stainless steel clamping provides superior connections; designed for ease of serviceability.
- Maintenance-free drive system; stainless steel drive chain does not require lubrication.
- Standby mode saves up to 75 percent energy during slow periods when unit is not in use and allows machine to quickly return to full power.
- Fan control switch senses temperature of unit and keeps fan running until unit is completely cool.
- Adjustable legs.
- 4½ ft. (1.4 m) cord with plug.
- Made in the USA.

CLEARANCE AND ENVIRONMENT REQUIREMENTS

- Do not place on surfaces or near walls, partitions or kitchen furniture unless they are made of non-combustible material or clad with non-combustible heat-insulating material. Toasters must not be used near or below curtains and other combustible materials.
- Maximum ambient temperature: 104° F (40 ° C).

Approvals	Date

The Vollrath Company, L.L.C. Headquarters
1236 North 18th Street
Sheboygan, Wisconsin
53081-3201 USA
Main Tel: 800-624-2051 or 920-457-4851
Main Fax: 800-752-5620 or 920-459-6573
Canada Customer Service: 800-695-8560
Tech Services: techservices@vollrathco.com
www.vollrath.com

Pujadas
Ctra. de Castanyet,
132 P.O. Box 121
17430 Santa Coloma de Farners
(Girona) – Spain
Tel. +34-972-84-32-01
info@pujadas.es

Vollrath of China
Vollrath Shanghai Trading Limited
Room 201, Building A
Xin Yi Plaza
1618 Yi Shan Road
Shanghai, 201103
China, P.R.C.
Tel: +86-21-5058-9580

Vollrath de Mexico S. de R.L. de C.V.
Periferico Sur No. 7980 Edificio 4-E
Col. Santa Maria Tequepexpan
45600 Tlaquepaque, Jalisco | Mexico
Tel: (52) 333-133-6767
Tel: (52) 333-133-6769
Fax: (52) 333-133-6768

INTERNATIONAL CONVEYOR TOASTERS - 950-1,000 SLICES PER HOUR* (JT3, JT3H)

DIMENSIONS (Shown in inches (cm))

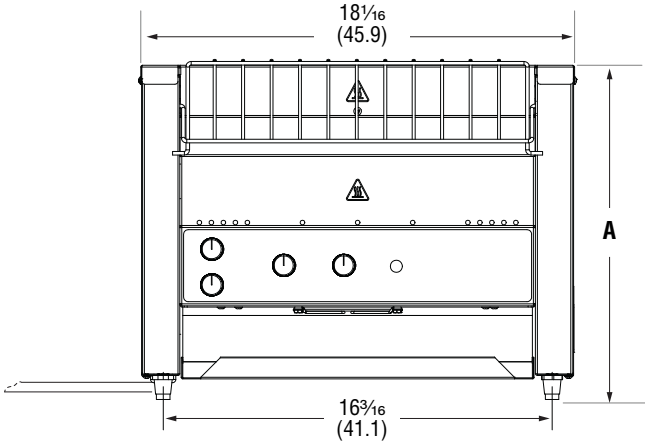

Front View

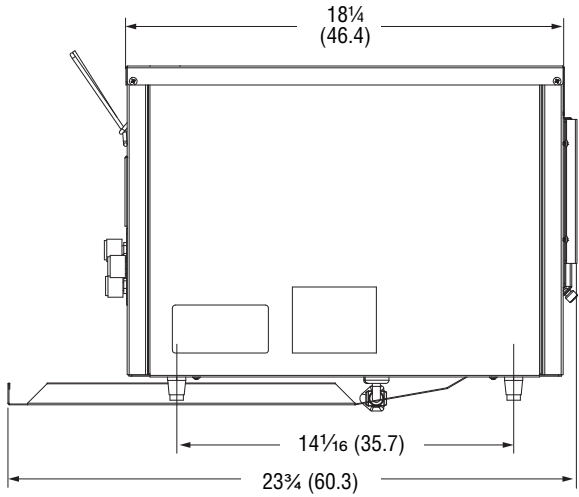

Side View

SPECIFICATIONS

Item No.	Model	Slices or Bun Halves Per Hour (Up To)*	Dimensions IN (CM)		Voltage	Maximum Watts	Amps	Hz	Weight LB (KG)	Plug
			Product Opening	(A) Height						
CT4-2301000	JT3	1,000	1½ (3.8)	14 (35.6)	220-240	3600	14.4	50/60	60 (27.2)	No plug. Stripped ends.
CT4H-230950	JT3H	950	Adjustable 1½ - 3 (3.8 - 7.6)	15 (38)					65 (29.5)	

* Slices per hour is based on maximum conveyor speed. Conveyor speed determines toasting time and affects color and texture of the toast. Results may vary based upon type of bread, color and texture preference.

The Vollrath Company, L.L.C. Headquarters
 1236 North 18th Street
 Sheboygan, Wisconsin
 53081-3201 USA
 Main Tel: 800-624-2051 or 920-457-4851
 Main Fax: 800-752-5620 or 920-459-6573
 Canada Customer Service: 800-695-8560
 Tech Services: techservicereps@vollrathco.com
 www.vollrath.com

Pujadas
 Ctra. de Castanyet,
 132 P.O. Box 121
 17430 Santa Coloma de Farners
 (Girona) – Spain
 Tel. +34-972-84-32-01
 info@pujadas.es

Vollrath of China
 Vollrath Shanghai Trading Limited
 Room 201, Building A
 Xin Yi Plaza
 1618 Yi Shan Road
 Shanghai, 201103
 China, P.R.C.
 Tel: +86-21-5058-9580

Vollrath de Mexico S. de R.L. de C.V.
 Periferico Sur No. 7980 Edificio 4-E
 Col. Santa Maria Tequepexpan
 45600 Tlaquepaque, Jalisco | Mexico
 Tel: (52) 333-133-6767
 Tel: (52) 333-133-6769
 Fax: (52) 333-133-6768