

FORMENTERA white WATERPROOF 350 x 350

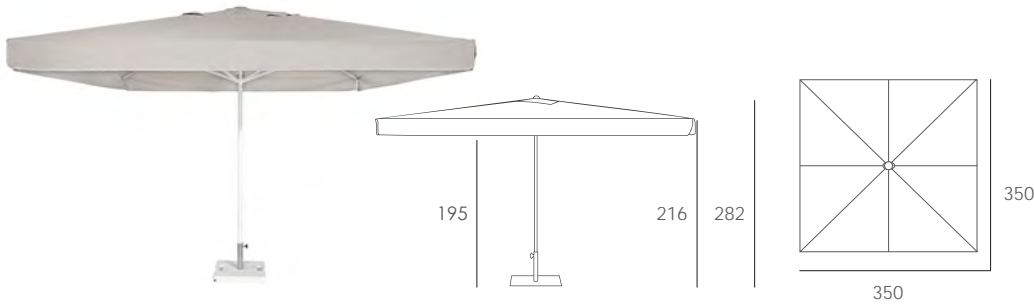

Valance with airvent
 REF.: **SGAP11C3500142P**
 Tube: ø50 mm
 Ribs: 8 | 30 x 20 x 1,2 mm

ES

Parasol impermeable de aluminio lacado en antracita. Mástil de una sección, accesorios de polipropileno y con sistema de apertura por poleas y pasador con 3 posiciones de ajuste. Producto de uso doméstico y público. Usar en superficies estables y planas. Cerrar en caso de fuertes vientos. Evite productos de limpieza agresivos.

PO

Guarda-sol impermeável em alumínio lacado em antracite. Haste de uma seção, acessórios de polipropileno e com sistema de abertura por roldanas com 3 posições de ajuste. Produto de uso doméstico e público. Use em superfícies estáveis e planas. Feche em caso de fortes rajadas de vento. Evite produtos de limpeza agressivos.

EN

Waterproof aluminium parasol lacquered in anthracite. Mast of a section, polypropylene accessories and with opening system by pulleys and pin with 3 adjustment positions. Domestic and public use product. Use on stable and flat surfaces. Close in case of strong wind streaks. Avoid aggressive cleaning products.

FR

Parasol imperméables aluminium laqué anthracite. Mât de section, accessoires en polypropylène et ouverture par poulies et goupille avec 3 positions de réglage. Produit à usage domestique et public. Utilisez sur des surfaces stables et plates. Fermer le parasol en cas de forte traînée de vent. Évitez les produits de nettoyage agressifs.

DETALLES / DETALHES / DETAILS / DÉTAILS



TEJIDO / TECIDO / FABRIC / TISSU

Sand waterproof 67% Polyester 33% PVC Fabric

Norma EN343: Highest level of rain protection

100P11

Sand Waterproof Fabric



DATOS LOGÍSTICOS/ DADOS LOGÍSTICOS / LOGISTIC DATA / DONNÉES LOGISTIQUES

Kg u.	CBM m3/u.	U. / Pallet Measurements	Pallet Weight	U. / Box Measurements	Truck	Container 40"
23,8 Kg	0,15 Kg	25 un. 291x116x130 cm	450 Kg	1 u. 291x22,5x22,5 cm	200 u.	200 u.

Made in Portugal

FORMENTERA anthracite WATERPROOF

350 x 350

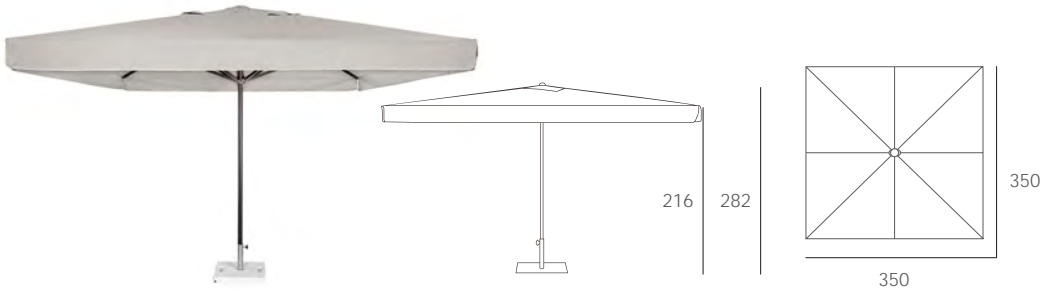

Valance with airvent

REF.: **SGAP11C3500342P**

Tube: ø50 mm

Ribs: 8 | 30 x 20 x 1,2 mm

ES

Parasol impermeable de aluminio lacado en antracita. Mástil de una sección, accesorios de polipropileno y con sistema de apertura por poleas y pasador con 3 posiciones de ajuste. Producto de uso doméstico y público. Usar en superficies estables y planas. Cerrar en caso de fuertes vientos. Evite productos de limpieza agresivos.

PO

Guarda-sol impermeável em alumínio lacado em antracite. Haste de uma seção, acessórios de polipropileno e com sistema de abertura por roldanas com 3 posições de ajuste. Produto de uso doméstico e público. Use em superfícies estáveis e planas. Feche em caso de fortes rajadas de vento. Evite produtos de limpeza agressivos.

EN

Waterproof aluminium parasol lacquered in anthracite. Mast of a section, polypropylene accessories and with opening system by pulleys and pin with 3 adjustment positions. Domestic and public use product. Use on stable and flat surfaces. Close in case of strong wind streaks. Avoid aggressive cleaning products.

FR

Parasol imperméables aluminium laqué anthracite. Mât de section, accessoires en polypropylène et ouverture par poulies et goupille avec 3 positions de réglage. Produit à usage domestique et public. Utilisez sur des surfaces stables et plates. Fermer le parasol en cas de forte traînée de vent. Évitez les produits de nettoyage agressifs.

DETALLES / DETALHES / DETAILS / DÉTAILS



TEJIDO / TECIDO / FABRIC / TISSU

Sand waterproof 67% Polyester 33% PVC Fabric

Norma EN343: Highest level of rain protection

100P11

Sand Waterproof Fabric



DATOS LOGÍSTICOS/ DADOS LOGÍSTICOS / LOGISTIC DATA / DONNÉES LOGISTIQUES

Kg u.	CBM m3/u.	U. / Pallet Measurements	Pallet Weight	U. / Box Measurements	Truck	Container 40"
23,8 Kg	0,15 Kg	25 un. 291x116x130 cm	450 Kg	1 u. 291x22,5x22,5 cm	200 u.	200 u.