

LAND REF. MN-LAN00

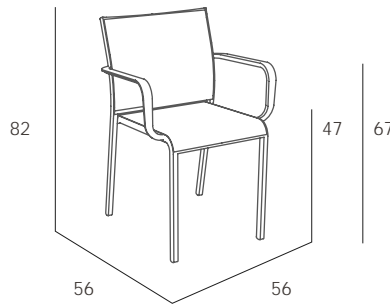

Leg: Ø 30 - Ø 25 mm



SGS

EN 581-1
EN 581-2

ES

Sillón apilable. Aluminio lacado. Tejido Phiferflex®, reemplazable. Tacos antideslizantes. Protección contra rayos UV y tratamiento antifúngico. Válido para uso en exterior. Producto de uso público y doméstico. Usar en superficies estables y planas. Limpiar con agua jabonosa. Evite productos de limpieza agresivos.

PO

Cadeira empilhável. Alumínio lacado. Tecido Phiferflex®. Tacos antiderrapantes. Válido para uso ao ar livre. Proteção contra os raios UV. Produto de uso público e doméstico. Use em superfícies estáveis e planas. Limpe com água e sabão. Evite produtos de limpeza agressivos.

EN

Stackable aluminium armchair. Lacquered. Phiferflex fabric, replaceable. Non slip caps. UV protection and with anti-fungal treatment. Suitable for outdoor use. Public and domestic use product. Use on stable and flat surfaces. Clean with soapy water. Avoid aggressive cleaning products.

FR

Fauteuil empilable. Aluminium laqué. Toile Phiferflex® remplaçable. Embouts antidérapants. Résistant aux rayons UV et soumis à un traitement antifongique. Peut être utilisé en extérieur. Produit à usage public et domestique. Utilisez sur des surfaces stables et plates. Nettoyer avec de l'eau savonneuse. Évitez les produits de nettoyage agressifs.

DETALLES / DETALHES / DETAILS / DÉTAILS

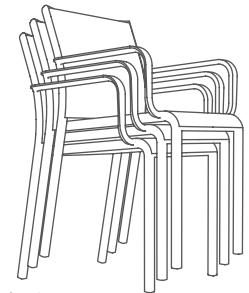

Stack 10

ACABADOS / ACABAMENTOS / FINISHES / FINITIONS

PHIFERTEX
Outdoor Fabrics

010T11	020T11	091T11
White	Taupe	Anthracite

DATOS LOGÍSTICOS / DADOS LOGÍSTICOS / LOGISTIC DATA / DONNÉES LOGISTIQUES

Kg u.	CBM m3/u.	U. / Pallet Measurements	Pallet Weight	U. / Box Measurements	Truck	Container 20"	Container 40"
3,50 Kg	0,08	40 u. 120x100x210 cm	154 Kg	2/4 u. 70,6x57,3x103,6 cm	1040 u.	400 u.	840 u.